



Features:

- ◆◆◆ Microsoft® Windows® CE .NET 4.2
- ◆◆◆ Intel® XScale™ Technology Processor - 200MHz standard (400MHz option)
- ◆◆◆ 64MB SDRAM
- ◆◆◆ Built-in Compact Flash partitioned for OS storage and application/data storage
- ◆◆◆ Internal Bluetooth® or Wi-Fi available (option)
- ◆◆◆ Lithium Battery-backed Real-Time Clock
- ◆◆◆ 320x240 QVGA-TFT color display with touch screen
- ◆◆◆ Standard or customized for your application
- ◆◆◆ IP 65 (option)
- ◆◆◆ Two (2) Year Warranty

Height: 9.84 inches
(250 mm)

Width (Display area):
4.75 inches (120.7 mm)

Width (Keypad area):
3.07 inches (78 mm)

Depth: 1.83 inches (46.5 mm)

Display Size (Active area):
2.82 x 2.11 inches
(71.62 mm x 53.60 mm)

Weight w/Rechargeable Battery:
29 ounces (822 grams)

Weight w/Alkaline Battery:
28 ounces (794 grams)

Weight w/o Battery:
23 ounces (652 grams)

JETT•ce

hand held computer ◆◆◆

Looking for the latest in hand held computer technology for industrial and commercial use? Designed for one-handed operation, the JETT•ce features a powerful Microsoft® Windows® CE .NET 4.2 operating system, Intel XScale® Technology Processor, color sunlight readable display with touch screen technology, and a variety of interface capabilities. The JETT•ce is an ideal solution to meet the complex and varied requirements of a wide range of applications.

The standard 320x240 pixel QVGA-TFT color display is sunlight readable with an LED backlight for easy viewing in high or low light conditions. The touch screen gives you the ability to create GUI based applications – providing unlimited possibilities for user control.

The JETT•ce comes standard with 64MB of SDRAM and 64MB of built-in Compact Flash (approximately 32MB used for operating system), which is expandable to 2GB. For removable data storage or I/O cards, the JETT•ce is equipped with a Compact Flash (CF) slot.

Featuring a variety of interface options, the JETT•ce comes standard with one RS-232 serial port. For applications that require dual serial port capability, a second serial port configured as RS-232, RS-422 or RS-485 is available.

The JETT•ce comes standard as a battery powered unit with a rechargeable Nickel Metal Hydride (NiMH) battery pack, which is interchangeable with AA Alkaline batteries. A line powered unit is also available.

Two Technologies now provides integrated wireless options for the JETT•ce. You can choose between WLAN 802.11b (Wi-Fi), Bluetooth® Class 1 or Bluetooth Class 2 when ordering a unit.

Two Technologies offers applications development services to our GEM Partners. Please be sure to contact us for more information.

As with all Two Technologies' products, the JETT•ce is specifically designed for industrial and commercial use. The case is molded from Xenoy®, one of the most durable, chemical-resistant materials available on the market today. Securely clamped into place, the keypad surface ensures excellent splash resistance and prevents curling or peeling of the keypad overlay.





JETT•ce Specifications

Display

- 320x240 pixel QVGA-TFT color (with white LED Backlight) • Touch screen

Keys, Switches & Indicators

- Standard or Custom graphics available • Standard or Custom Layouts: 45-key membrane (10 rows x 4 columns plus 1 x 5 bottom row), 45-key elastomeric, 30-key elastomeric (10 x 3), 15-key elastomeric (5x3) • Custom Layouts available • Feedback: Tactile and Audible • Power/Resume switch: 5 programmable LED Indicators (2nd, Alt, Caps Lock, Shift, Ctrl), one fixed LED for Low battery/Charge status (battery unit only) • Optional Backlit keypad • 8 Definable "Hot" Keys- Can be used to execute or automate programs.

Interface

- One RS-232 Serial Port is standard • Optional second serial port with a choice of RS-232, RS-422 or RS-485
- Optional internal Wi-Fi (802.11b) • Optional internal Bluetooth® (class 1 or 2)

Power

- Nickel Metal Hydride rechargeable batteries (1400 mAH, 7.2V) • AA Alkaline batteries (6)
- Recharge/Line Power: 11 to 18 VDC, 1.5A • 8 hours minimum operating time

Environment

- Storage temperature: -20° to +70°C • Operating temperature: -20° to + 50°C
- Charging temperature: -20° to + 40°C • Humidity: 5-95% (non-condensing)

Memory & Mass Storage

- 64MB Compact Flash built-in (approximately 32MB used for operating system) • Expandable to 2GB
- 64MB SDRAM

CPU/Operating System

- Microsoft® Windows® CE .NET 4.2 • Intel® XScale™ Technology processor - 200MHz standard (400MHz Option)

Custom Options

- Line Powered Unit • Customizable options: Case Color, Bumper Color, LED Logo Tag (elastomeric keypad only), Keypad Layout (quantity of keys and locations), Keypad Graphics, Logo Tag, LED Colors, Serial Tag, Cables and Pin-outs.

Certifications

- FCC Class A • EN55022, 1998. (CISPR 22) Class A, EN55022/IEC 6100-4-6 RF CONTINUOUS CONDUCTED
- EN55024, 1998 - ETSI EN 301489-1,2002 - ETSI EN 301489-3,2002 - EN/IEC 61000-4-2 ESD - EN/IEC 61000-4-3 RF ELECTROMAGNETIC FIELD - EN/IEC 61000-4-4 FAST TRANSIENTS • EN60950:2000

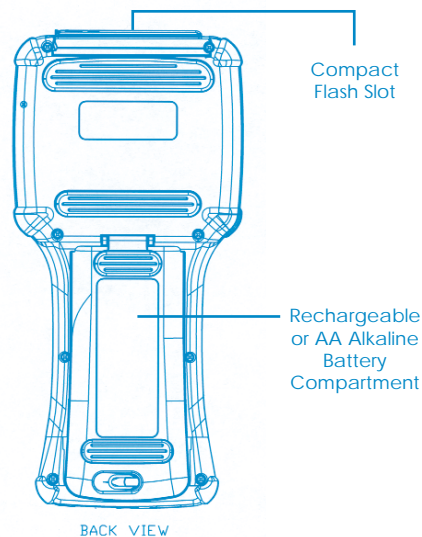
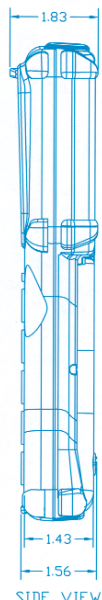
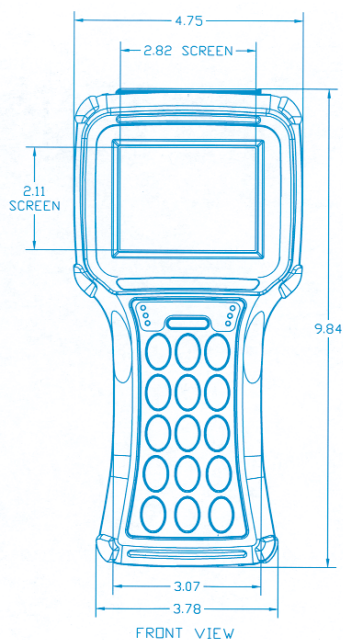

Dimensions